

MATEMATIKUPPGIFTER

FÖRSKOLA - HÖST

Namn: _____

Jag är:

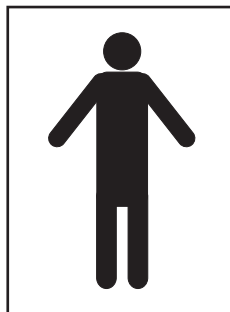

Klass/grupp: _____

Datum: _____

Totalpoäng: ____ / 48p



2
FMS: Jämförelse

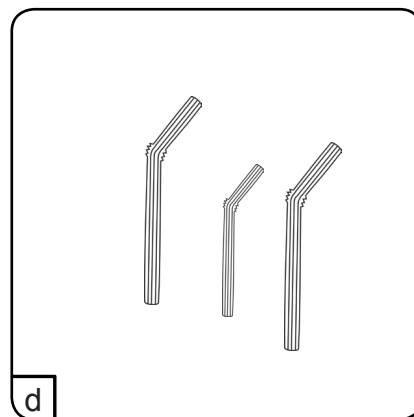
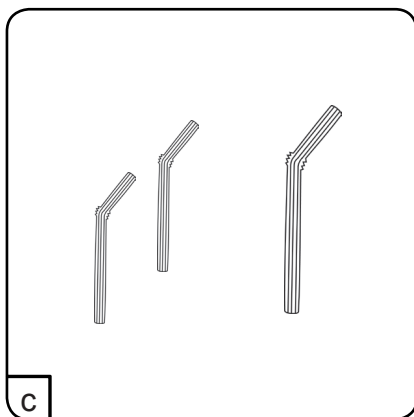
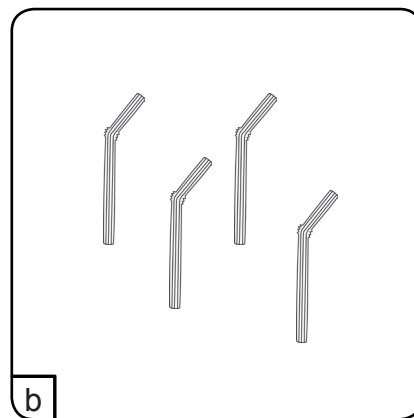
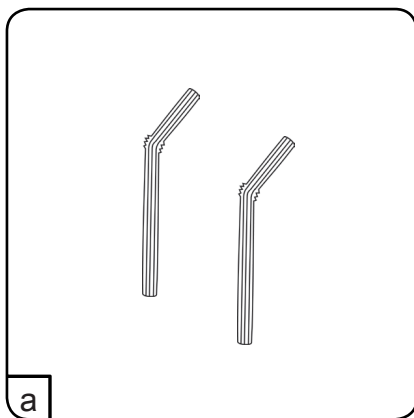
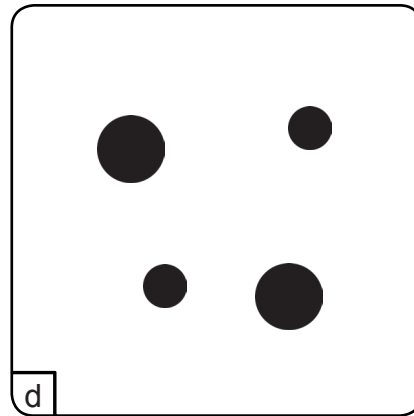
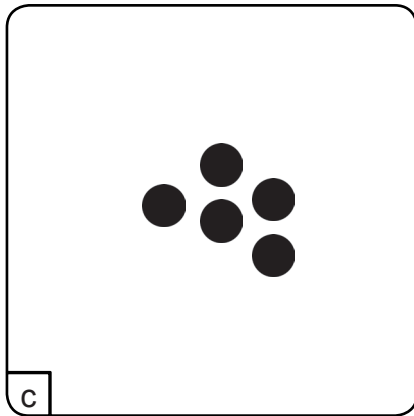
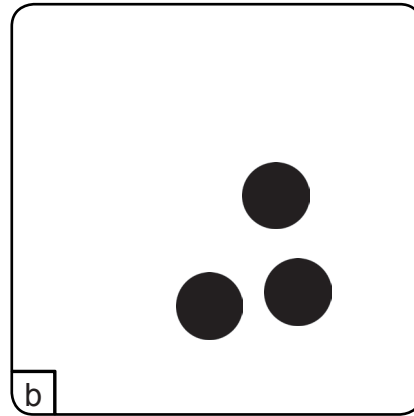
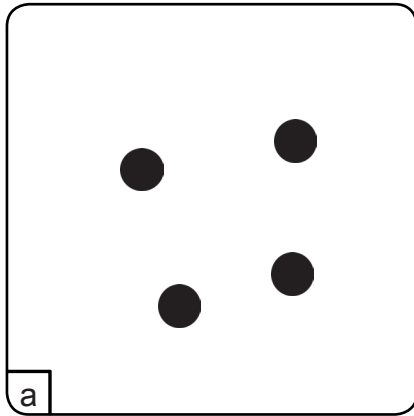

_____ / 2p

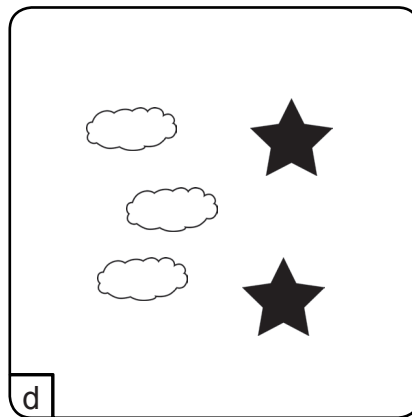
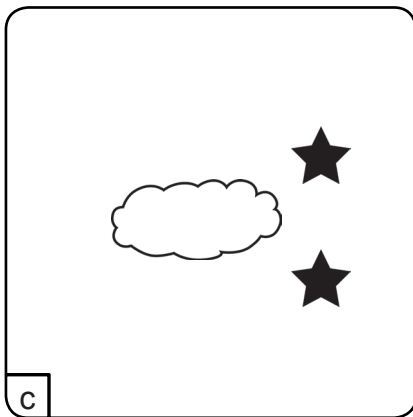
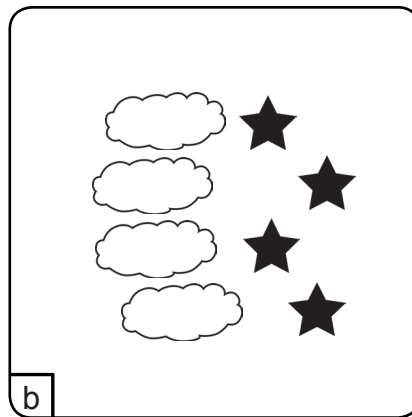
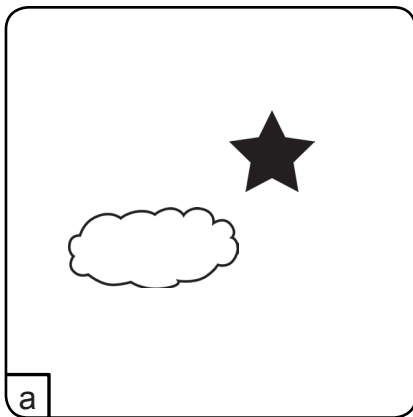
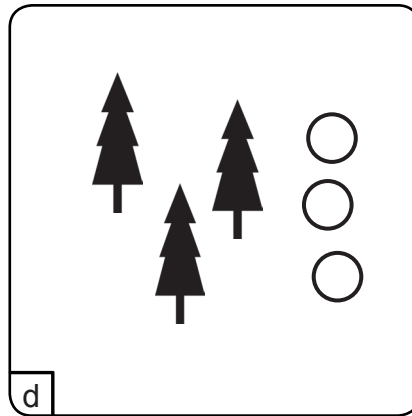
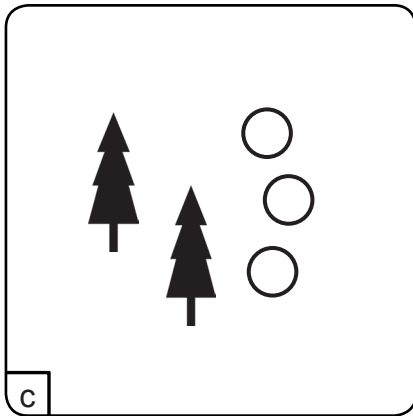
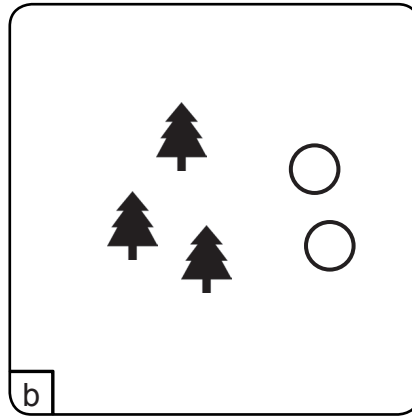
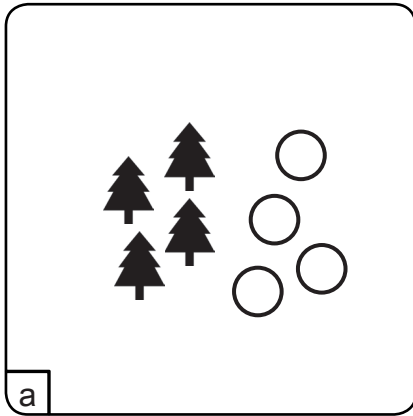

_____ / 2p



4
FMS: Jämförelse

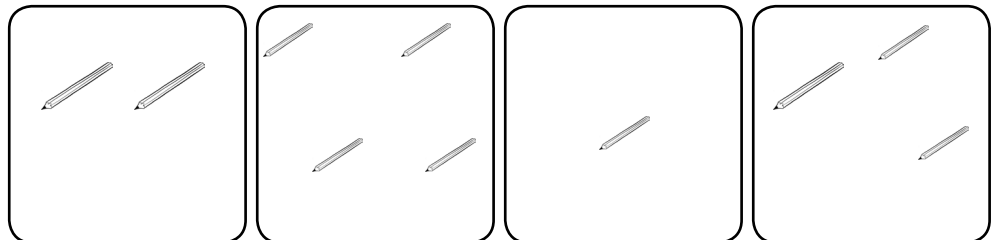
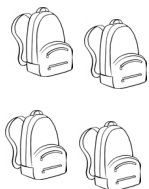
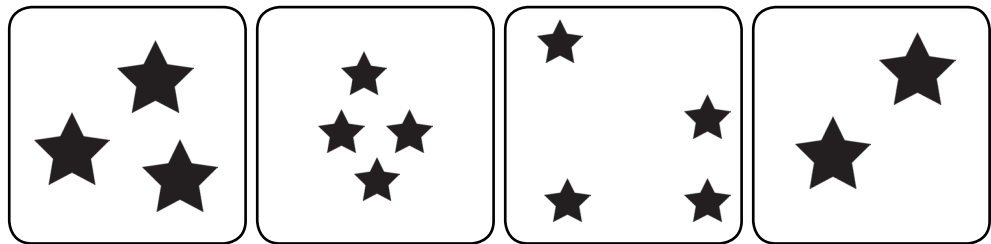
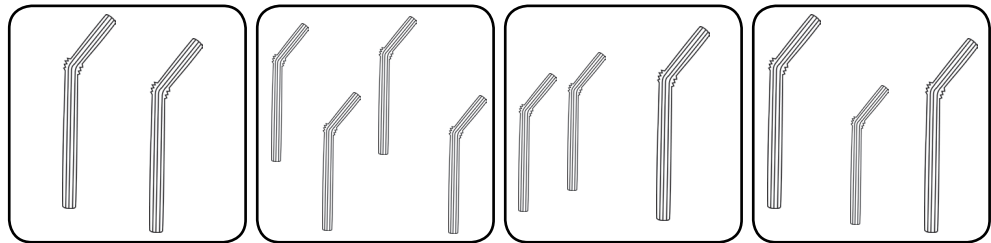
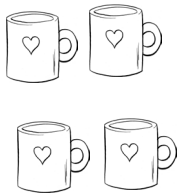
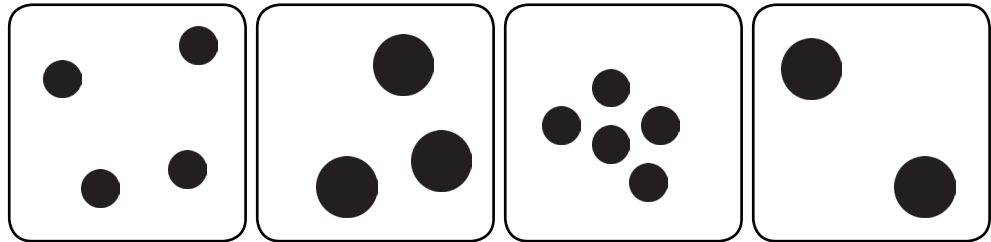
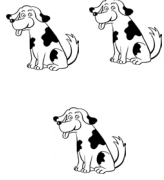

_____ / 4p

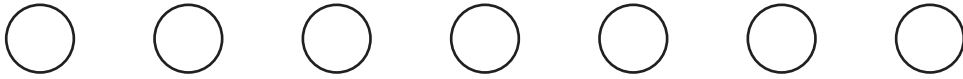
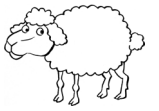

_____ / 4p



6
FMS: Talföljder





_____ / 2p

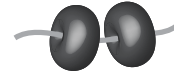
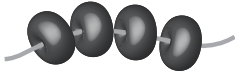
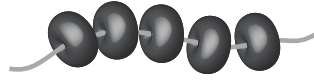

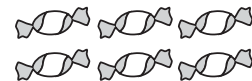
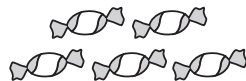
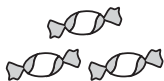
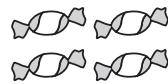

_____ / 2p



	5	4	6
---	---	---	---

	7	5	4
---	---	---	---

	9	7	10
---	---	---	----

	6	8	7
---	---	---	---

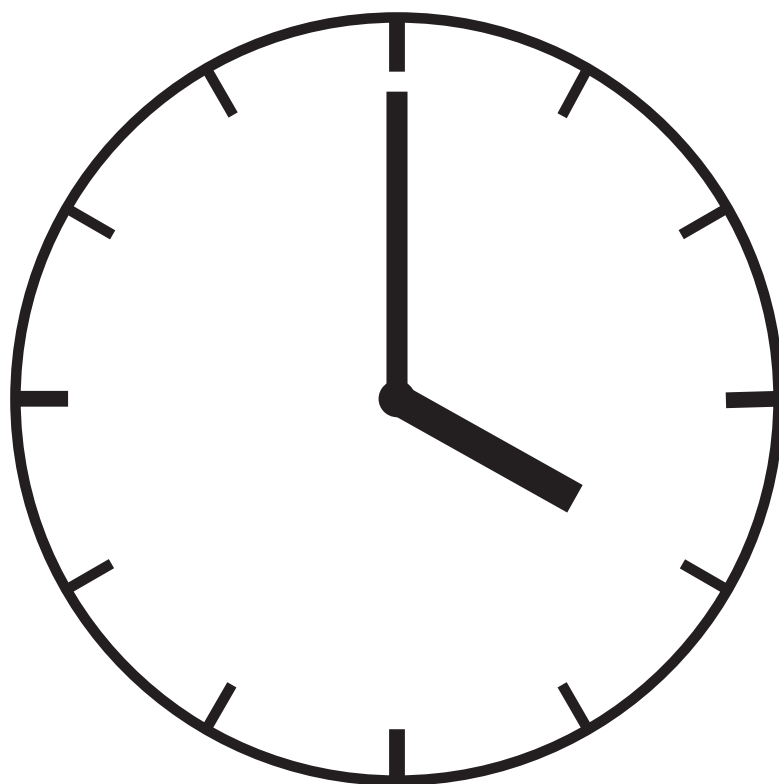

PAUS



4 7 3



5 4 6

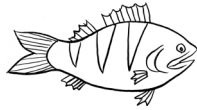

6 5 8

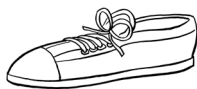

9 4 7

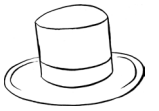

7 5 4



6 10 8

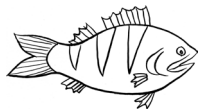

4 5 3

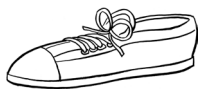

9 7 4



● ● ● ●	● ● ●	● ● ● ● ●
---------	-------	-----------



● ● ● ● ● ● ● ● ● ●	● ● ● ● ● ● ● ● ● ●	● ● ● ● ● ● ● ● ●
------------------------	------------------------	----------------------

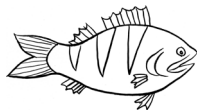

7	6	4
---	---	---



9	11	10
---	----	----



	8	6	9
---	---	---	---

	7	6	5
---	---	---	---

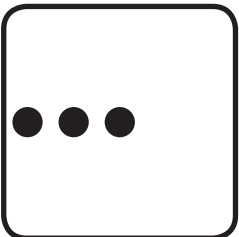
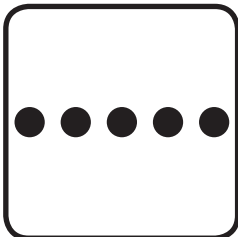
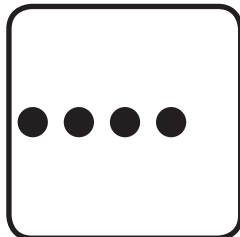
4			
---	---	--	---

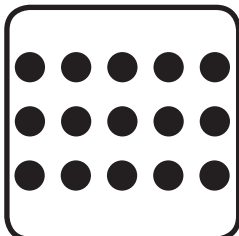
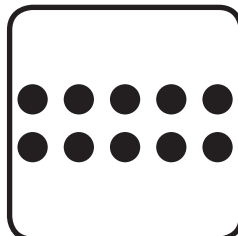
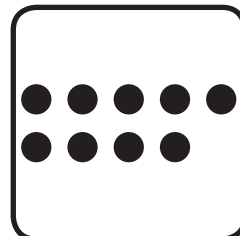
10			
----	---	--	---

____ / 4p



	$3 - 1 = 2$
---	-------------

	$0 + 2 = 2$
---	-------------

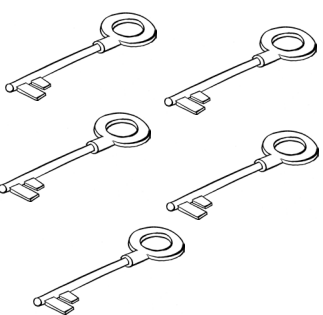
	$2 + 3 = 5$
---	-------------

	$8 + 2 = 10$
---	--------------

____ / 4p

UPPRÄKNING AV TALRADEN

Följande tre uppgifter utförs individuellt med varje barn. Uppgifterna räcker ca 5 minuter.

- Anteckna i talraden ifall barnet avviker från det korrekta uppräknandet. Ifall barnet korrigerar sig själv behöver det inte antecknas (t.ex. 1, 2, 4, nej, det är ju 1, 2, 3, 4).
- Sätt slutligen kryss på ”behärskar” på de talområden som barnet uppräknar helt felfritt. Sätt kryss på ”behärskar inte” ifall barnet inte behärskar uppräknandet eller gör fel.

UPPRÄKNING AV TALRADEN FRAMÅT

Jag skulle vilja veta hur långt du kan räkna. Börja med talet ett. Om barnet avbryter innan talet 30 skall du uppmuntra barnet att fortsätta. Då barnet har nått talet 30 kan du avbryta genom att säga: **Bra, det räcker.**

1 2 3 4 5 6 7 8 9 10 11 12 13 14 15 16 17 18 19 20 21 22 23 24 25 26 27 28 29 30

1→10 behärskar ___ /behärskar inte ___

11→20 behärskar ___ /behärskar inte ___

21→30 behärskar ___ /behärskar inte ___

UPPRÄKNING AV TALRADEN FRÅN ETT GIVET TAL

Nu räknar vi framåt. Börja med talet fyra. Om barnet avbryter före barnet har uppräknat de fyra följande talen, uppmuntra då barnet att fortsätta. Då barnet har uppräknat de fyra följande talen kan du avbryta genom att säga: **Bra, det räcker.** (Uppräknandet är korrekt endast om barnet börjat från det givna talet eller från följande tal.) Om barnet klarade uppgiften ger du en ny uppgift: **Nu får du räkna igen. Börja nu med talet 9.** Då barnet uppräknat de fyra följande talen korrekt kan du avbryta genom att säga: **Bra, det räcker.** Om barnet klarade uppgiften ger du ytterligare en uppgift: **Vi skall ännu räkna framåt. Börja med talet 17.** Om barnet uppräknar de fyra följande talen korrekt kan du avbryta genom att säga: **Bra, det räcker.**

4 5 6 7 8 9 10 11 12 13 17 18 19 20 21

4→8 behärskar ___ /behärskar inte ___

9→13 behärskar ___ /behärskar inte ___

17→21 behärskar ___ /behärskar inte ___

UPPRÄKNING AV TALRADEN BAKÅT

Nu vill jag veta om du kan räkna bakåt. Börja med talet fem. Om barnet börjar räkna framåt skall du avbryta och upprepa instruktionen en gång: **Nu räknar vi bakåt. Börja med talet 5.** Då barnet kommer till talet ett säger du: **Bra, det räcker.** Om barnet klarade uppgiften ger du en ny uppgift: **Nu får du räkna igen. Räkna bakåt. Börja nu med talet 12.** Då barnet kommer till talet 8 säger du: **Bra, det räcker.**

5 4 3 2 1

12 11 10 9 8

5→1 behärskar ___ /behärskar inte ___

12→8 behärskar ___ /behärskar inte ___

Varje del som barnet behärskar ger 1 poäng.